

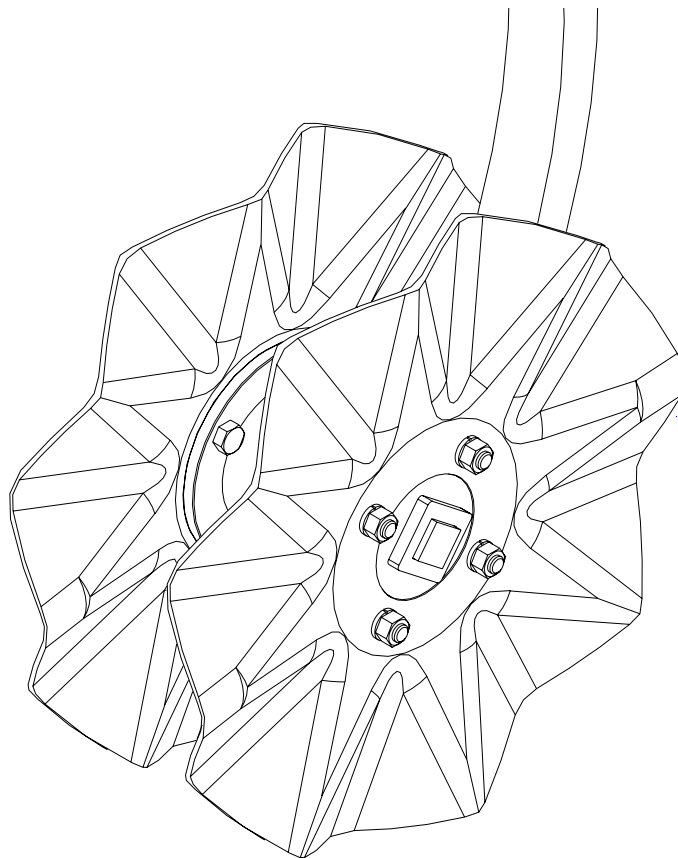

# VERTICAL TILLAGE ATTACHMENT



## ASSEMBLY, OPERATORS & PARTS MANUAL



PO Box 1030  
Wahpeton, ND 58074  
PH (701) 642-2621  
Fax (701) 642-3372  
[WWW.WIL-RICH.COM](http://WWW.WIL-RICH.COM)

VERTICAL TILLAGE ASSY/PART (79958) 8/09

# Front Mount Vertical Disk Assembly

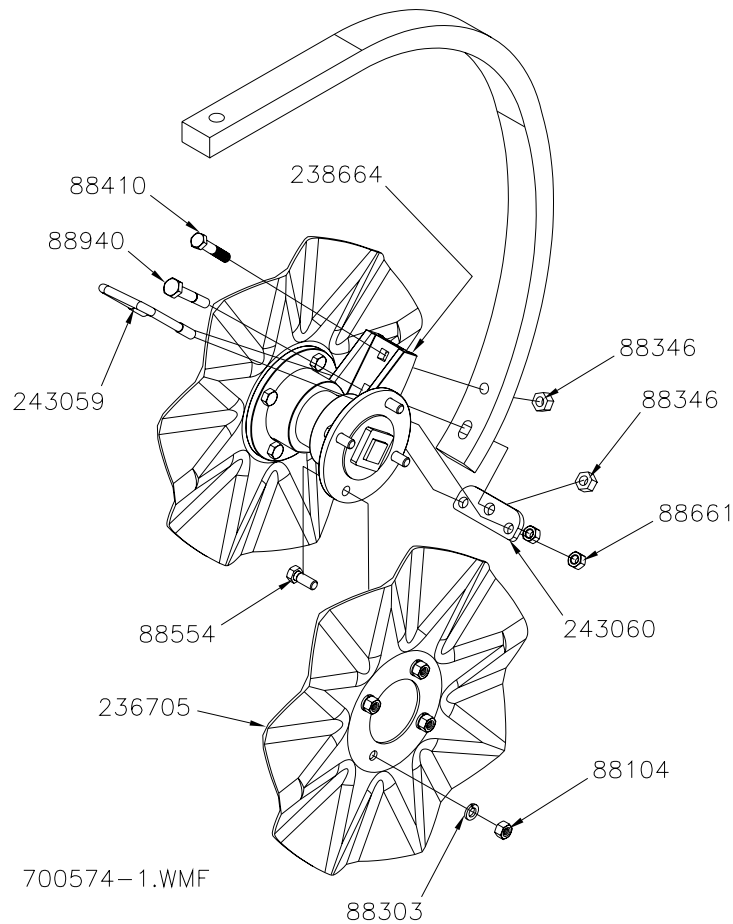

PART NO.	DESCRIPTION	QTY
234048	3/4" - 12 WAVE BLADE	2
236705	17" DIA COULTER BLADE 8 WAVE-1 3/4"	2
238664	CUTTER HUB ASSY - 2006	1
243059	BLT-U 1/2-13NCX2 3/4 X 4 1/4	1
243060	SUPPORT PLATE	1
88104	NUT HEX 1/2-13NC 5Z	8
88303	WSHR HLK 1/2ID(9/16ACT) Z	8
88346	NUT HVY 1/2-13NC 5P	2
88410	BLT HEX 1/2-13NCX2-1/2 5Z	1
88554	BLT HEX 1/2-13NCX1-1/4 5Z	8
88661	NUT TOP LK 1/2-13NC 5Z	2
88940	BLT HEX 1/2-13NC X 3 8YZ	1

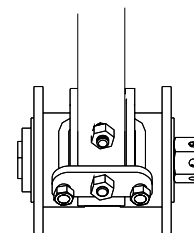
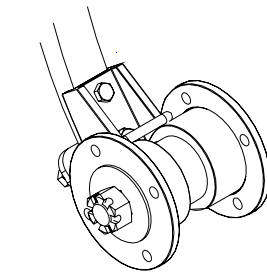

700574-4

# Rear Mount Vertical Disk Assembly

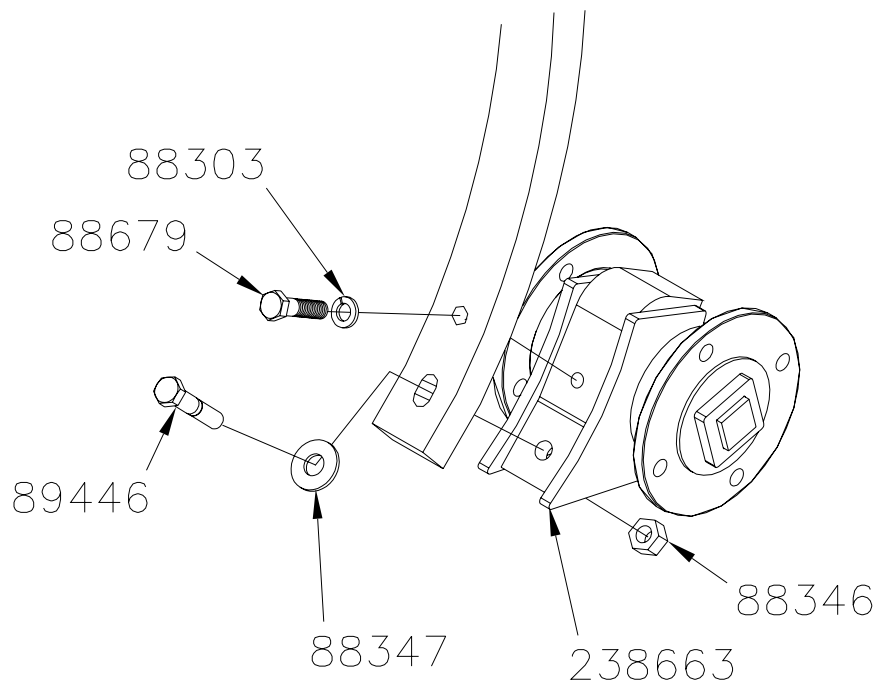

700574-2.WMF 8/3/09

PART NO.	DESCRIPTION	QTY
238663	REAR CUTTER HUB ASSY - 2006	1
88303	WSHR HLK 1/2ID(9/16ACT) Z	1
88346	NUT HVY 1/2-13NC 5P	1
88347	WSHR FLAT 1/2(9/16X1-3/8ACT) Z	1
88679	BLT HEX 1/2-13NCX2 5Z	1
89446	BLT HEX 1/2-13NCX2-1/2 8Z	1

## MOUNTING INFORMATION

Mount the front vertical disk to the front of the chisel shank as shown on Page 2. Insert the top mount bolt (88410) to position the disc hub. Insert the lower bolt (88940) through the hub, shank and support plate, loosely secure with the heavy nut (88346). Position the U-bolt over the hub as shown and through the support plate, secure with the lock nuts (88661). Once hub is positioned, tighten the hub bolts, followed by the U-bolt nuts.

Secure the rear mount hub as shown. These hubs are for use on shanks where a tire or other interference precludes the use of the front mount cutters. Mount the appropriate cutter blades to the hubs and secure.

After 3-4 hours of use re-torque all mounting hardware and occasionally during extended use.

# Front Mount Hub Assembly/Parts

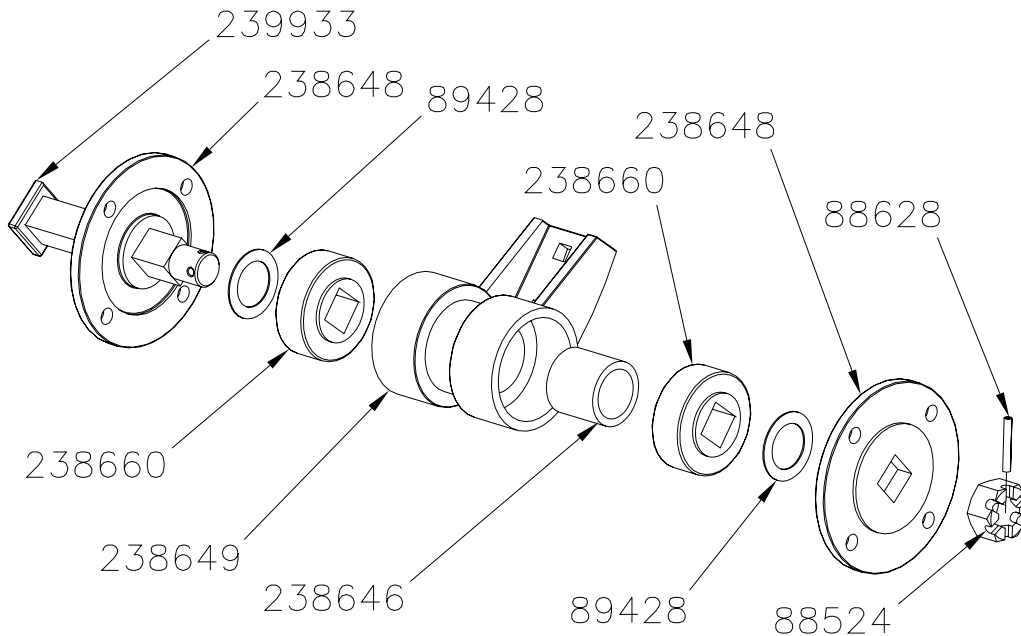

700574-5.WMF 5/27/08

PART NO.	DESCRIPTION	QTY
239933	FORGED CUTTER PIN	1
238660	1-1/8 SQR BEARING (W208PPB12)	2
238649	DISC CUTTER PIVOT - 2006 MACHINED	1
238648	DISK BLADE HUB - MACHINED	2
238646	INNER BEARING BUSHING	1
89428	BSHG MCHRY 1-1/2X2-1/4X18GA PLN	2
88628	PIN ROLL 1/4DIA X 1-3/4 Z	1
88524	NUT SLTD 1-1/8-7NC Z	1

## Hub Assembly Information

Insert the inner bearing bushing into the hub, bearings need to be press fit into the hub (PRESS BEARING ON BOTH THE INNER HUB AND OUTER RACE WHEN ASSEMBLING) from each side. Make certain the inner races of the bearings are tight against the inner bearing bushing. Once bearings are tight in the hub, insert the cutter pin into the disc blade hub, stack the machinery bushing on the pin, align and insert into the square bore bearing. Place opposite machinery bushing on the pin, assemble the disc hub and secure with the slotted nut.

Torque the nut to a minimum of 500 ft. lbs. Align a slot in the nut to the closest cross hole in the cutter pin and drive in spring pin.

Maintenance of the individual hubs should be minimal, the bearings are greaseless and need no lubrication. Maintain the tightness of the hardware that secures the hub to the chisel plow shank.

# Rear Mount Hub Assembly/Parts

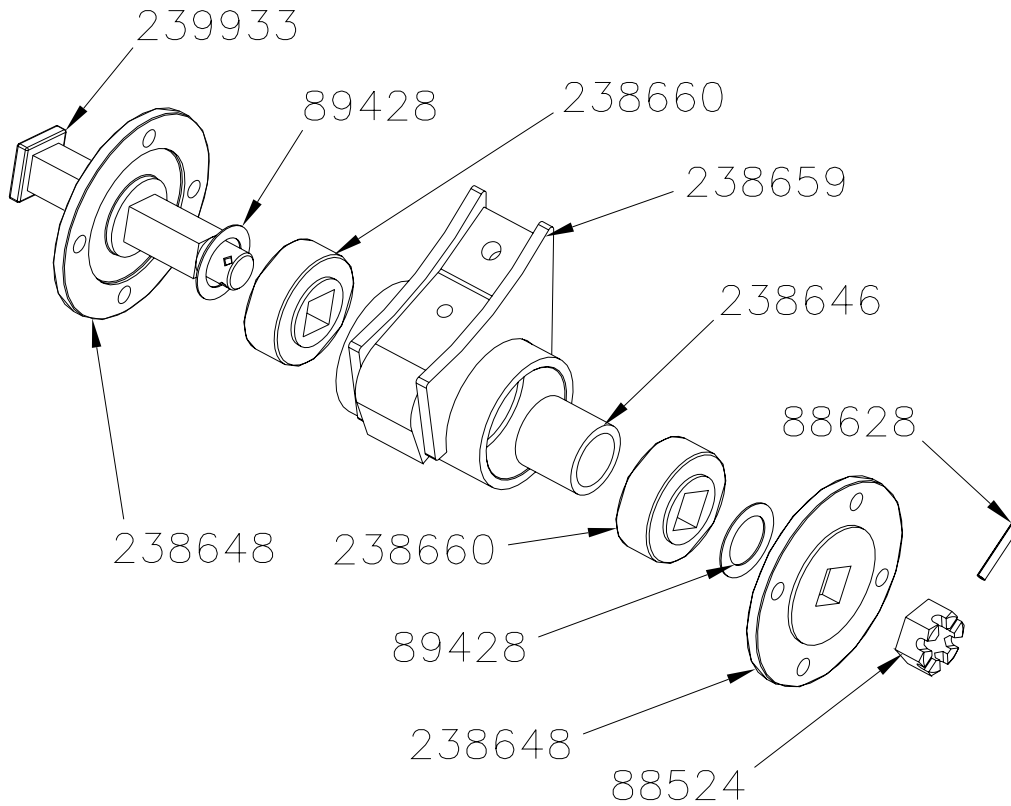

700574-6.WMF 5/27/08

PART NO.	DESCRIPTION	QTY
239933	FORGED CUTTER PIN	1
238660	1-1/8 SQR BEARING (W208PPB12)	2
238659	REAR MOUNT HUB - 2006	1
238648	DISK BLADE HUB - MACHINED	2
238646	INNER BEARING BUSHING	1
89428	BSHG MCHRY 1-1/2X2-1/4X18GA PLN	2
88628	PIN ROLL 1/4DIAX1-3/4 Z	1
88524	NUT SLTD 1-1/8-7NC Z	1