



OPERATOR'S MANUAL

WIL-RICH 957 DISK RIPPER



WIL-RICH

PO Box 1030

Wahpeton, ND 58074

PH (701) 642-2621

Fax (701) 642-3372

Parts Fax (701) 642-3819

WARRANTY

The only warranty Wil-Rich gives and the only warranty the dealer is authorized to give is as follows:

We warrant products sold by us to be in accordance with our published specifications or those specifications agreed to by us in writing at time of sale. Our obligation and liability under this warranty is expressly limited to repairing, or replacing, at our option, within 12 months after date of retail delivery, any product not meeting the specifications. *We make no other warranty, express or implied and make no warranty of merchantability or of fitness for any particular purpose.* Our obligation under the warranty shall not include any transportation charges or costs or installation or any liability for direct, indirect or consequential damage or delay. If requested by us, products or parts for which a warranty claim is made are to be returned transportation prepaid to our factory. Any improper use, operation beyond rated capacity, substitution of parts not approved by us, or any alteration or repair by others in such manner as in our judgment affects the product materially and adversely shall void this warranty. *No employee or representative is authorized to change this warranty in any way or grant any other warranty.*

Wil-Rich reserves the right to make improvement changes on any of our products without notice.

When warranty limited or not applicable: Warranty on hoses, cylinders, hubs, spindles, engines, valves, pumps or other trade accessories are limited to the warranties made by the respective manufactures of these components. Rubber tires and tubes are warranted directly by the respective tire manufacturer only, and not by Wil-Rich.

Warranty does not apply to any machine or part which has been repaired or altered in any way so as in the our judgment to affect its reliability, or which has been subject to misuse, negligence or accident.

A Warranty Validation and Delivery Report Form must be filled out and received by Wil-Rich to initiate the warranty coverage.

WARRANTY CLAIMS PROCEDURE

1. The warranty form must be returned to Wil-Rich within fifteen (15) working days from the repair date.
2. Parts returned to Wil-Rich without authorization will be refused. The parts must be retained at the dealership for ninety (90) days after the claim has been filed. If the Service Department would like to inspect the parts, a packing slip will be mailed to the dealer. The packing slip must be returned with the parts. The parts must be returned prepaid within thirty (30) days of receiving authorization. After the parts are inspected and warranty is verified, credit for the return freight will be issued to the dealer.
3. Parts that will be scrapped at the dealership will be inspected by a Wil-Rich Sales Representative, District Sales Manager or Service Representative within the ninety (90) day retaining period.

TO THE OWNER

It is the responsibility of the user to read the Operator's Manual and comply with the safe and correct operating procedures as pertains to the operation, lubrication and maintenance of the product according to the information outlined in the Operator's Manual.

If this machine is used by an employee or is loaned or rented, make certain that the operator(s), prior to operating, is instructed in safe and proper use and reviews and understands the Operator's Manual.

The user is responsible for inspecting his/her machine and for having parts repaired or replaced when continued use of this product would cause damage or excessive wear to the other parts. The word NOTE is used to convey information that is out of context with the manual text; special information such as specifications, techniques, reference information of supplementary nature.

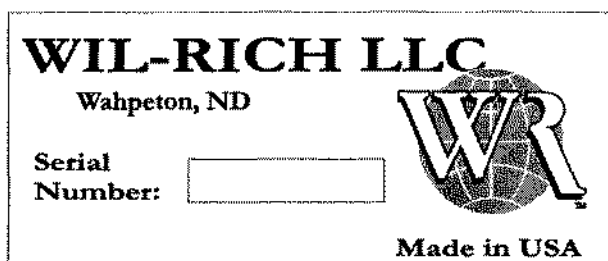

When in need of parts, always specify the model and serial number. Write this number in the space provided. The serial number plate is on the left front main tube.

MODIFICATIONS

It is the policy of Wil-Rich to improve its products whenever possible and practical to do so. We reserve the right to make changes, improvements and modifications at any time without incurring obligation to make such changes, improvements on any equipment sold previously.

TRADEMARKS

Other product and company names mentioned herein may be trademarks of their respective owners. The use of these names are for reference only, Wil-Rich uses the names only to aid in distinguishing different setups of the Ripper.

CONTENTS

MODIFICATIONS	3
TRADEMARKS	3
TO THE OWNER	3
GENERAL INFORMATION	4
SAFETY	5
GERNERAL SAFETY	6
HYDRAULIC SAFETY	7
TRANSPORT SAFETY	7
STORAGE SAFETY	8
TIRE SAFETY	8
SAFETY DECALS	8
SIGN-OFF FORM	9
SAFETY DECAL LOCATIONS	10-11
SAFETY LIGHTS	12
OPERATIONAL INFORMATION	
DISK GANG	13
RIPPER SHANKS	13
HARROW ASSEMBLY	13
OPERATIONAL PARAMETERS	14
PREFIELD ADJUSTMENTS	
UNIT & TRACTOR PREP	14
FIELD ADJUSTMENTS	15-16
RIPPER SHANK DEPTH	17-18
DISK GANG DEPTH	18
TRANSPORT SETTINGS	19
HARROW OPERATION	20-21
TINE ANGLE ADJUSTMENT	22
LUBRICATION	24-26
TROUBLE SHOOTING	27

GENERAL INFORMATION

Wherever the terms "left" and "right" are used, it must be understood to mean from a position behind and facing the machine.

Lubricate all bearings and moving parts as you proceed and make sure they work freely.

Loosely install all bolts connecting mating parts before final tightening.

When tightening bolts, they must be torqued to the proper number of foot-pounds as indicated in the table unless specified. It is important that all bolts be kept tight.

On new machines, all nuts and bolts must be re-checked after a few hours of operation.

When replacing a bolt, use only a bolt of the same grade or higher. Except in shear bolt applications, where you must use the same grade bolt.

	GRADE 2		GRADE 5			GRADE 8	
TORQUE IN FOOT POUNDS							
BOLT DIA	3/8	1/2	5/8	3/4	7/8	1	
HEX HEAD	9/16	3/4	15/16	1-1/8	1-5/16	1-1/2	
UNC GR2	18	45	89	160	252	320	
UNC GR5	30	68	140	240	360	544	
UNC GR8	40	100	196	340	528	792	
UNF GR2	21	51	102	178	272	368	
UNF GR5	32	70	168	264	392	572	
UNF GR8	48	112	216	368	792	840	

TORQUE.EPS

Bolts with no markings are grade 2

Grade 5 bolts furnished with the machine are identified by three radial lines on the head.

Grade 8 bolts furnished with the machine are identified by six radial lines on the head.

All U-bolts are grade 5.

CAUTION

TO AVOID POSSIBLE INJURY:

- Always lower implement to the ground for servicing or when not in use.
- Never allow anyone to ride on implement.
- Keep everyone clear of tractor and implement while in use or while tractor is running.

31926

PERSONAL SAFETY IS IMPORTANT!

ALL PERSONNEL INVOLVED WITH THE ASSEMBLY AND/OR OPERATION OF THIS EQUIPMENT MUST BE INFORMED OF PROPER SAFETY PROCEDURES. OPERATOR'S/ ASSEMBLY MANUALS PROVIDE THE NECESSARY INFORMATION. IF THE MANUAL IS LOST FOR A PARTICULAR IMPLEMENT, ORDER A REPLACEMENT AT ONCE. OPERATOR'S AND ASSEMBLY MANUALS ARE AVAILABLE AT NO CHARGE UPON REQUEST.

This Safety Alert symbol means **ATTENTION! BECOME ALERT YOUR SAFETY IS INVOLVED!**

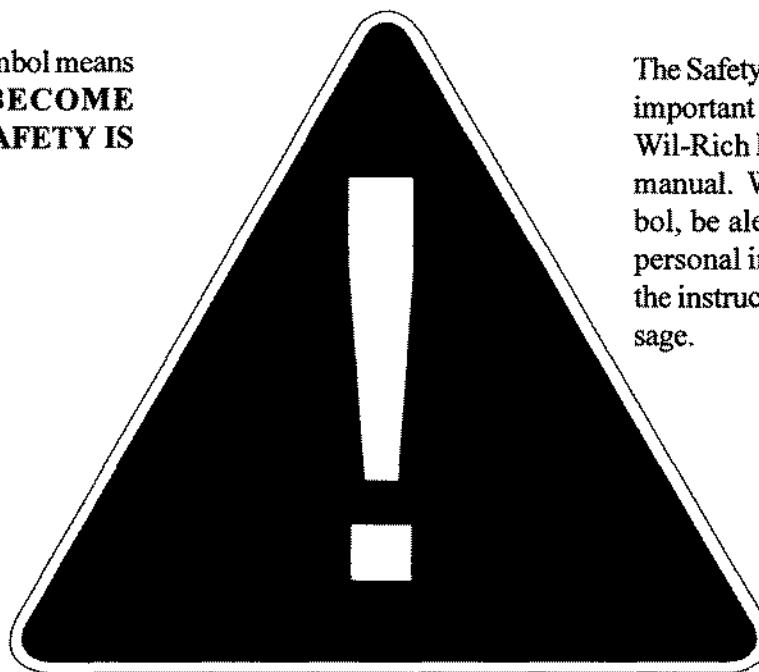

The Safety Alert symbol identifies important safety messages on the Wil-Rich Disk Ripper and in this manual. When you see this symbol, be alert to the possibility of personal injury or death. Follow the instructions in the safety message.

Why is SAFETY important to you?

3 Big Reasons

Accidents Disable and Kill

Accidents Cost

Accidents Can Be Avoided

SIGNAL WORDS:

Note the use of the signal words **DANGER**, **WARNING** and **CAUTION** with the safety messages. The appropriate signal word for each message has been selected using the following guidelines:

DANGER

An immediate and specific hazard which **WILL** result in severe personal injury or death if the proper precautions are not taken.

WARNING

A specific hazard or unsafe practice which **COULD** result in severe personal injury or death if the proper precautions are not taken

CAUTION

Unsafe practices which **COULD** result in personal injury if proper practices are not taken, or as a reminder of good safety practices.

ADDRESS INQUIRIES TO: WIL-RICH PO BOX 1030
WAHPETON, ND 58074
PH (701) 642-2621 FAX (701) 642-3372

SAFETY

YOU are responsible for SAFE operation and maintenance of your Wil-Rich 957 Disk Ripper. You must ensure that you and anyone else who is going to operate, maintain or work around the Disk Ripper be familiar with the operating and maintenance procedures and related safety information contained in this manual. This manual will take you step by step through your working day, alerts you to all good safety practices that should be adhered to while operating this equipment.



Remember, YOU are the key to safety. Good safety practices not only protect you but also the people around you. Make these practices a working part of your safety program. Be certain that EVERYONE operating this equipment is familiar with the recommended operating and maintenance procedures and follows all safety precautions. Most accidents can be prevented. Do not risk injury or death by ignoring good safety practices.

957 Disk Ripper owners must give operating instructions to operators and employees before allowing them to operate the Disk Ripper, and at least annually thereafter per OSHA regulation 1928.57.

The most important safety device on this equipment is a safe operator. It is the operator's responsibility to read and understand ALL Safety and Operating instructions in the manual and to follow them. All accidents can be avoided.

A person who has not read and understood all operating and safety instructions is not qualified to operate the machine. An untrained operator exposes themselves and bystanders to possible serious injury or death.

Do not modify the equipment in any way. Unauthorized modifications may impair the function and/or safety and could affect the life of the equipment.

Think SAFETY! Work SAFELY!

General Safety

Read and understand the operator's manual and all safety signs before operating, maintaining or adjusting the 957 DiskRipper.

Install and properly secure all shields and guards before operating.

Have a first-aid kit available for use should the need arise and know how to use it.

Have a fire extinguisher available for use should the need arise and know how to use it.

Clear the area of people and remove foreign objects from the machine before starting and operating.

Always wear relatively tight and belted clothing to avoid entanglement in moving parts. Wear sturdy, rough-soled work shoes and protective equipment for eyes, hair, hands, hearing and head.

Do not allow riders.

Wear suitable ear protection for prolonged exposure to excessive noise.

Stop tractor engine, place all controls in neutral, set park brake, remove ignition key and wait for all moving parts to stop before servicing, adjusting, repairing or unplugging.

Review safety related items with all operators annually

TO AVOID INJURY OR MACHINE DAMAGE:

- **BEFORE OPERATING:** Study Operators Manual, safety messages and safe operating procedures, read safety signs on this machine.
- **Transport on public roads -** Observe Federal, State and Local regulations; display SMV emblem; Attach proper strength implement safety chain; and limit maximum speed to 20mph (32km/h).
- **Lower or block all elevated components before servicing or leveling this machine.**

2427

HYDRAULIC SAFETY

Always place all tractor hydraulic controls in neutral before dismounting.

Make sure that all components in the hydraulic system are kept in good condition and are clean.

Relieve pressure before working on hydraulic system.

Replace any worn, cut, abraded, flattened or crimped hoses and metal lines.

Do not attempt any makeshift repairs to the hydraulic lines, fittings or hoses by using tape, clamps or cements. The hydraulic system operates under extremely high-pressure. Such repairs will fail suddenly and create a hazardous and unsafe condition.

Wear proper hand and eye protection when searching for high pressure leaks. Use a piece of cardboard as a backstop instead of hands to isolate and identify a leak.

If injured by a concentrated high-pressure stream of hydraulic fluid, seek medical attention immediately. Serious infection or toxic reaction can develop from hydraulic fluid piercing the skin surface.

Before applying pressure to the system, make sure all components are tight and that lines, hoses and couplings are not damaged.

Think SAFETY! Work SAFELY!



The sign features a large exclamation mark at the top. Below it are two icons: a hand being struck by a hose and a person wearing safety glasses. The text below the icons reads: **HIGH PRESSURE FLUID HAZARD**
To prevent serious injury or death:

- Relieve pressure on system before repairing or adjusting or disconnecting.
- Wear proper hand and eye protection when searching for leaks. Use wood or cardboard instead of hands.
- Keep all components in good repair.

60711

TRANSPORT SAFETY

Read and understand ALL the information in the Operator's Manual regarding procedures and SAFETY when moving Disk Ripper in the field/yard or on the road.

Check with local authorities regarding transportation on public roads. Obey all applicable laws and regulations.

Always travel at a safe speed. Use caution when making corners or meeting traffic.

Make sure SMV (Slow Moving Vehicle) emblem and all lights and reflectors that are required by the local highway and transport authorities are in place, are clean and can be seen clearly by all overtaking and oncoming traffic

Use a drawbar pin with provisions for a mechanical retainer.

Attach a safety chain before moving.

Keep to the right and yield the right-of-way to allow faster traffic to pass. Drive on the road shoulder, if permitted by law.

Always use hazard warning flashers on tractor when transporting unless prohibited by law.

Do not allow riders.

Do not exceed 20 m.p.h. during transport.

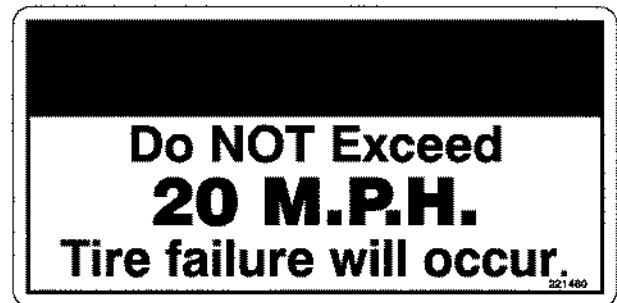

**Do NOT Exceed
20 M.P.H.
Tire failure will occur.**

221480

STORAGE SAFETY

Store unit in an area away from human activity.

Do not permit children to play around the stored unit.

Store in a dry, level area. Support the base with planks if required.

TIRE SAFETY

Failure to follow proper procedures when mounting a tire on a wheel or rim can produce an explosion which may result in serious injury or death.

Do not attempt to mount a tire unless you have the proper equipment and experience to do the job.

Have a qualified tire dealer or repair service perform required tire maintenance.

SAFETY DECALS

Keep safety decals and signs clean and legible at all times.

Replace safety decals and signs that are missing or have become illegible.

Replaced parts that displayed a safety sign should also display the current sign.

Safety decals or signs are available from your Dealer Parts Department.

How to install Safety Decals:

Be sure that the installation area is clean and dry.

Decide on the exact position before you remove the backing paper.

Remove the smallest portion of the split backing paper.

Align the decal over the specified area and carefully press the small portion with the exposed sticky backing in place.

Slowly peel back the remaining paper and carefully smooth the remaining portion of the decal in place.

Small air pockets can be pierced with a pin and smoothed out using the piece of decal backing paper.

SIGN-OFF FORM

WIL-RICH follows the general standard specified by the American Society of Agricultural Engineers (ASAE) and the Occupational Safety and Health Administration (OSHA). Anyone who will be operating and/or maintaining the 957 Disk Ripper must read and understand ALL Safety, Operation, and Maintenance information presented in this manual.

Do not operate or allow anyone else to operate this equipment until such information is reviewed. Annually review this information before the season start-up.

Make periodic reviews of SAFETY and OPERATION a standard practice for all your equipment. We feel that an untrained operator is unqualified to operate this machine.

A sign-off sheet is provided for all personnel who will be working with equipment have read and understood the information in the operators Manual and have been instructed in the operation of the equipment.

DATE	EMPLOYEE'S SIGNATURE	EMPLOYER'S SIGNATURE

SAFETY DECAL & SERIAL # LOCATIONS

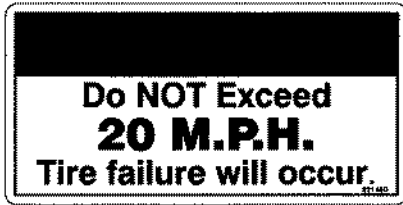

221480 TIRE SPEED DECAL

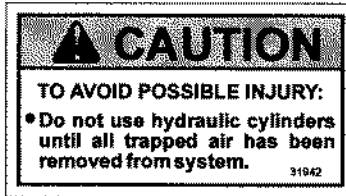

31942 CAUTION DECAL

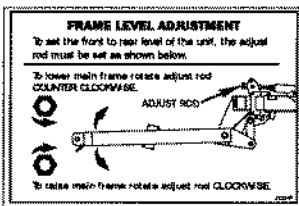
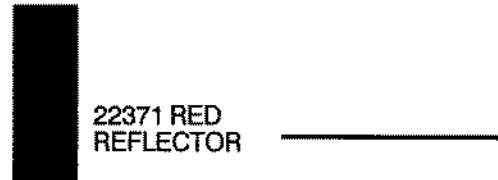

222248 FRAME LEVELING DECAL

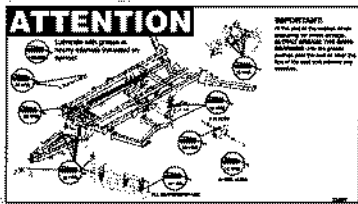

238397 GREASE DECAL

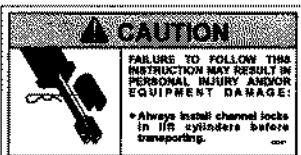

69387 CHANNEL LOCK DECAL

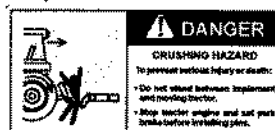

222802 CRUSHING HAZARD

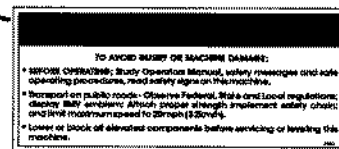

24227 SERVICE DECAL

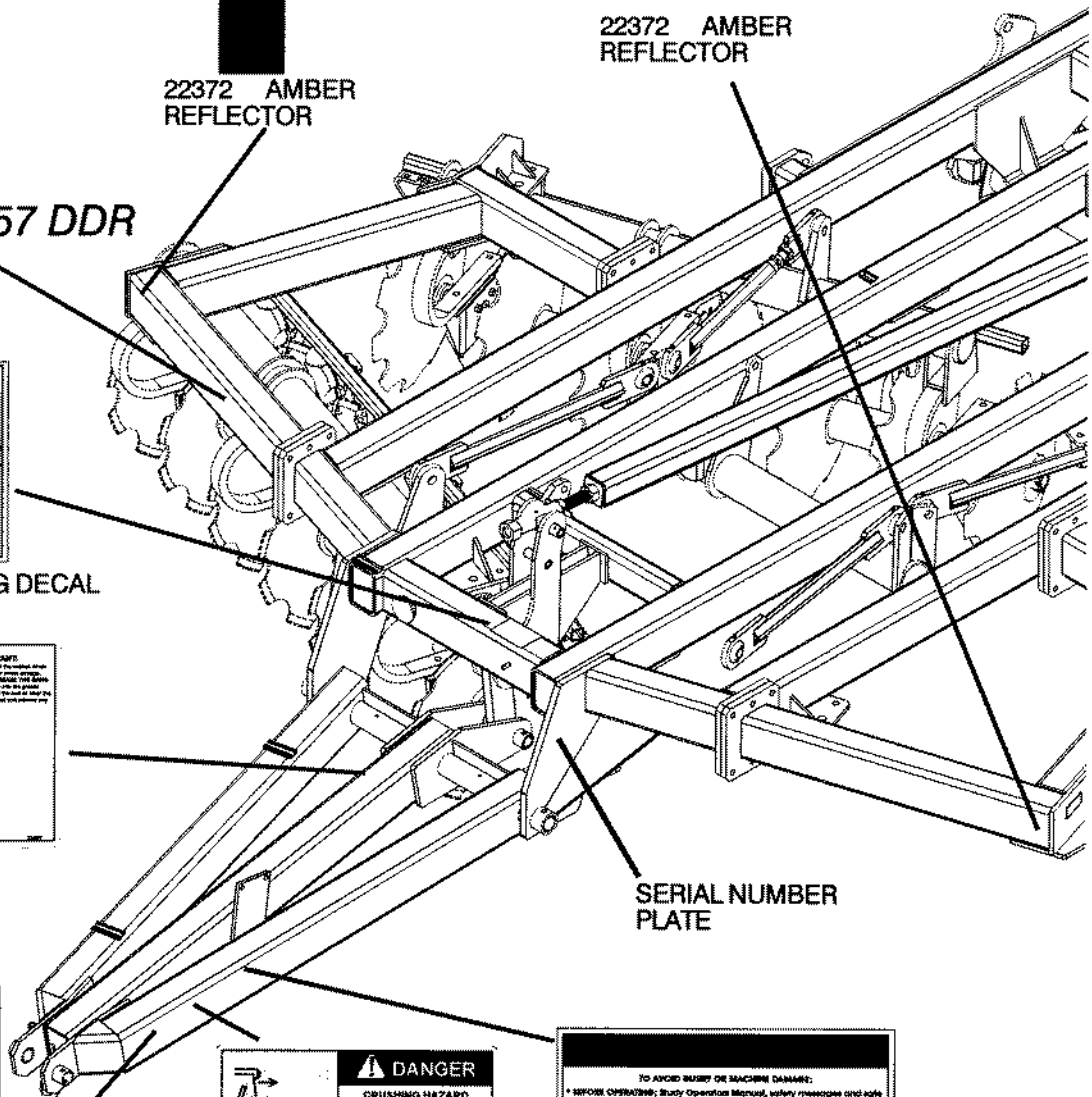



41345 SMV KIT

	CRUSHING HAZARD KEEP AWAY
	To prevent serious injury or death from crushing: <ul style="list-style-type: none"> • Stay away from shank area when shank is resetting. • Do not try to reset shanks by hand. • Keep all bystanders away.

221481 PINCH DECAL
ONE (1) ON EACH SHANK ASSY

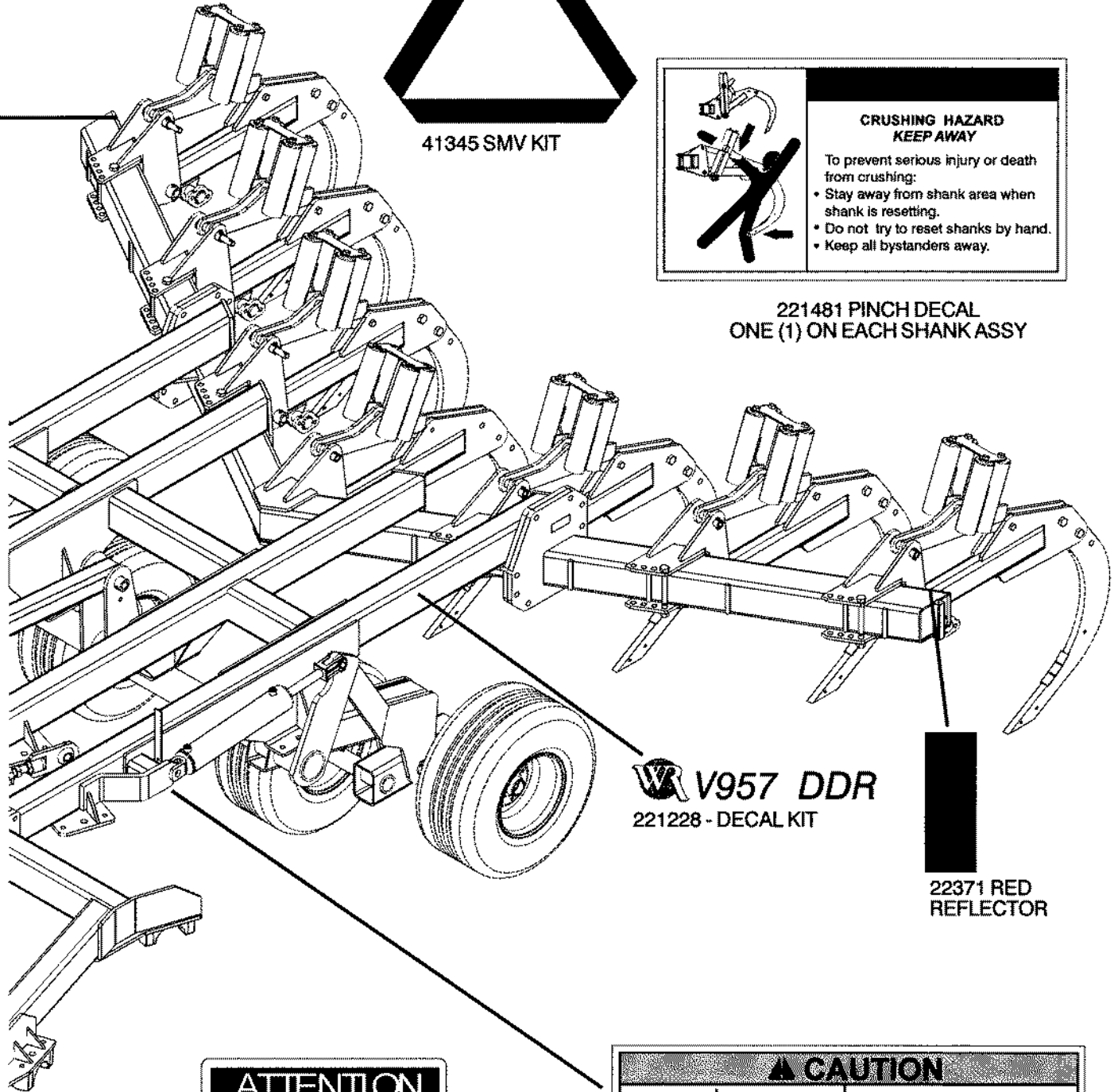

V957 DDR
221228 - DECAL KIT



22371 RED REFLECTOR

ATTENTION
Grease Fittings

62557 GREASE FITTING DECAL
(SEE LUBRICATION PAGE OPERATION)

CAUTION	
	FAILURE TO FOLLOW THIS INSTRUCTIONS MAY RESULT IN PERSONAL INJURY AND/OR EQUIPMENT DAMAGE:
	• Always install transport locks on lift cylinders before transporting.

222686 TRANSPORT LOCK DECAL

SAFETY LIGHTS



221141 CLEARANCE LIGHT PACKAGE

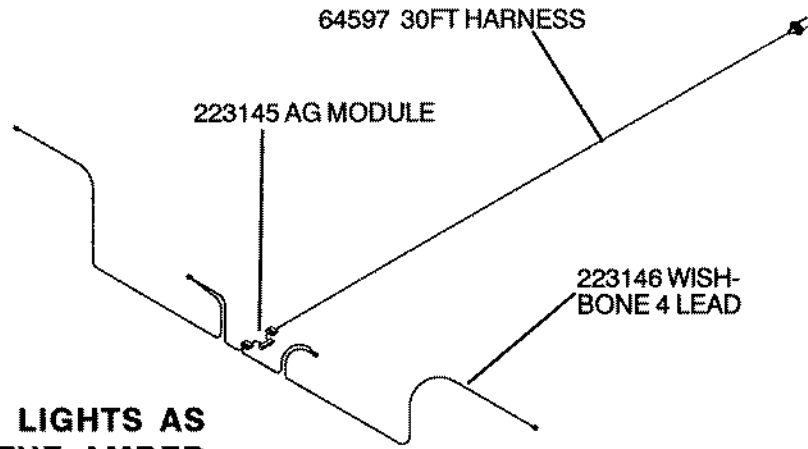

NOTE: MOUNT AMBER LIGHTS AS WIDE AS POSSIBLE. THE AMBER LIGHTS MUST BE MOUNTED NO MORE THAN 16" FROM THE IMPLEMENT EXTREMITIES.

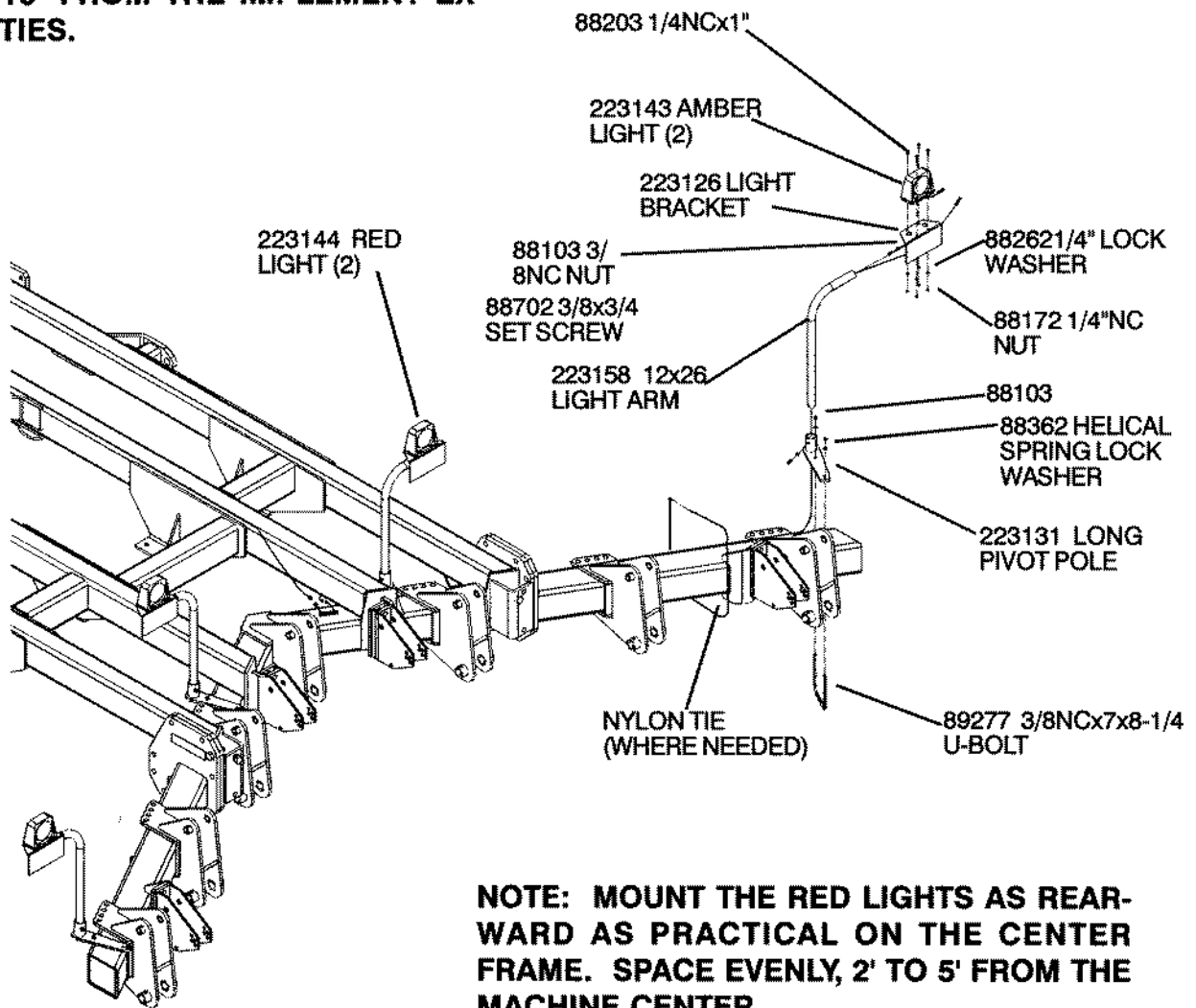

NOTE: MOUNT THE RED LIGHTS AS REARWARD AS PRACTICAL ON THE CENTER FRAME. SPACE EVENLY, 2' TO 5' FROM THE MACHINE CENTER.

OPERATIONAL INFORMATION

The WIL-RICH 957 Disk Ripper is designed as a primary tillage tool. The large diameter double disk gangs will cut and turn the soil, size and mix heavy residue. The ripper shanks can be equipped with straight or winged points to lift and fracture the ground. Equipped with the optional heavy coil tine harrow the soil can be tilled and leveled to a smooth finish.

Disk Gangs

The diamond configured disk gang consists of 28" diameter, 3/8" thick shallow concavity blades on 15" spacing. The gangs are mounted on a 2-3/16" diameter gang shaft and hung on self-aligning bearing mounts. The bearing mounts are fastened to heavy C-springs for impact relief. The complete gang is mounted to hydraulically controlled rock shafts.

The diamond configuration of the gangs minimizes the ridging of the rear gangs that can occur on the more common X-configured double disk arrangements. The C-springs allow the gangs to move and decrease the stress on the unit when contacting hidden obstacles. NOTE: though the disk gangs are designed of heavy components and incorporate spring relief, operating the disk gang at depth in areas of heavy rocks or hidden obstacles can increase the damage to bearings, blades and gangs.

The disk gangs are positioned to properly cut the trash with the rear blades cutting the trash in the center of the front blades. NOTE: this even cutting is only present when the gangs are rotated down to the deepest position (4 x 12 cylinder is fully extended). It is recommended that the disk gangs be run in the lowest position. This will maximize the even cutting of the trash. The disk gangs will function in a raised position and can be adjusted as trash conditions dictate.

The large 28" diameter blades combined with the 15" spacing and shallow concavity blades work to cut and mix the soil up to 7" – 8" deep in heavy trash conditions.

Ripper Shanks

The shanks are designed to operate below the ground tilled by the front disks. The spring-loaded shanks are a positive release design; the shanks do not float or move until the trip pressure is reached. This ensures that the shanks are maintained at the set operating depth until a load that exceeds the factory set point pressure is reached. Once the trip pressure is exceeded the shank will move up over the obstruction to a trip height of 16". Once the obstacle has been cleared the shank will return to operating depth.

The shank has two mounting positions consisting of a set of three holes. As shown in Figure #1 the normal shank setting is in the upper two holes. This places the shank at its maximum depth, approximately 7" – 8" below the bottom of the disk gang when the disk gang is set in the recommended lowest position. Moving the shank to the lower two holes will raise the shank approximately 5".

The current complement of WIL-RICH ripper points can be mounted to the shank. When operating the disk gangs at depth the ground that the points encounter has been partially worked. With the shanks set below the disk gang depth you will be fracturing the soil. For more fracturing the winged point can be used.

Harrow Assemblies

The heavy coil tine harrow will spread and mix the trash and soil to give the field a finish look. When the disk gangs are set to cut the trash and till the top 5" – 6" of the soil this heavy harrow has sufficient weight and tine strength to do an efficient job of leveling without the cost, complexity and reliability of rotating disks.

OPERATIONAL PARAMETERS

Maximum Depth - 12" to 16"

Operating Speed - 4.5 to 6 M.P.H.

Disk Depth - 3" to 8" Depending on operator preference (See disk Levelling)

Maximum Transport Speed - 20 M.P.H.

Horsepower Requirements -
40hp-60 PTO hp/shank - dependent on soil and operating conditions

For initial preparation of the 957 Disk Ripper, lubricate the lift wheel axles, hitch and disk gage pivots and ripper shanks as outlined the lubrication section of this manual (See page 22 & 23).

Tire pressure should be checked regularly and maintained as follows:

12.5L-15 (12PLY) Tire Assembly – 55 PSI

31 x 13.5L (12PLY) Tire Assembly – 65 PSI

16.5 x 22.5 (18PLY) Tire Assembly - 100 PSI

PRE-FIELD ADJUSTMENTS

Unit and Tractor Preparation

Consult your dealer for information on the minimum tractor horsepower requirements and tractor capabilities. Tractor requirements will vary with the type of points, operational depth of disk gangs and shanks, options and terrain. The front hitch weight at the draw bar of a 7 shank unit is approximately 4200 lbs. Provision may need to be made to carry this weight, your tractor may require a hitch support to carry the weight of the unit.

Make sure the tractor draw bar is in a stationary position. Place the wear plate below the disk ripper hitch on top of the tractor hitch. This plate is required to decrease wear of the tractor lower hitch bar. Attach the tractor to the disk ripper hitch with a hitch pin of sufficient size to carry the draw bar weight and load. Make certain the hitch pin is secured with a locking pin or cotter pin. Attach the safety chain. Clean off all hose ends to remove any dirt before connecting to the tractor. Connect the hydraulic hoses to the tractor ports in a sequence that is both familiar and comfortable to the operator. Raise the jack to the storage position by lowering the weight of the unit to the tractor with the crank and re-pinning in the storage position.

For proper operation of the Disk Ripper it is important that the unit be level.

The front to rear level of the unit is maintained by adjusting the leveling adjustment bolt at the front center of the unit (See Fig 2).

Check that the ripper is properly hitched to the tractor that will be powering the unit. On a flat area of the yard lower the frame so the shank points are 1" to 2" above the ground.

Measure down to the ground from a point at the front and rear of the unit as shown in FIG 2.

If the front of the unit is lower than the rear the leveling tube will need to be shortened. Shorten the tube and raise the front of the unit by turning the adjustment bolt in (CLOCK WISE). To lower the front of the unit lengthen the tube by turning the adjustment bolt out (COUNTER CLOCK WISE).

FIELD ADJUSTMENTS

Operating Depth Setting and Levelling

The ripper shanks can be set in a deep or shallow working position by mounting the shank in the upper or lower mounting holes. Normal factory assembled position is in the upper holes which will place the shank at the maximum depth position. This is the recommended operating position as it allows the shanks to work at a reasonable depth and also allows the disk gang to be run in it's lowest position. If more disking depth relative to the shank depth is desired the shank can be raised to the lower holes.

UPPER MOUNTING HOLES

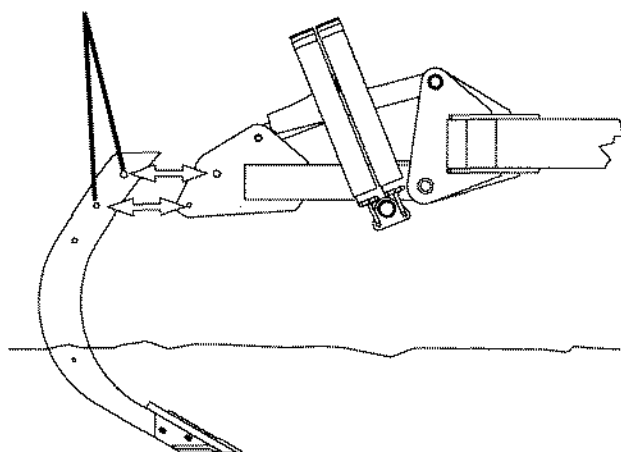

LOWER MOUNTING HOLES

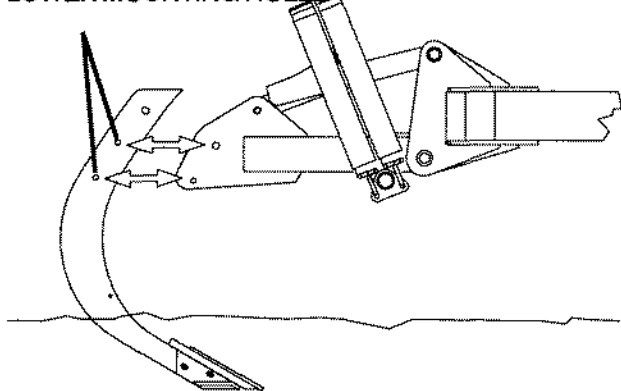

FIG. 1

1. In a level area of the field set the main frame down to where the shanks are resting on the ground. Measure the distance "A" from the bottom of the frame to the ground. (See Fig.2)
2. Raise the disk gangs so that the gang does not hold the front of the unit out of the ground. Move forward with the unit and lower the shanks into the ground.
3. Measure the main frame at location "B" and "C" as shown. (See Fig. 3)
4. Loosen the levelling nut and adjust the levelling adjustment bolt as required unit "B" and "C" are equal. Use the wrench provided to turn the leveling adjustment bolt. (See Fig. 4)
5. With the unit in the ground measure the distance "D" at the same location you measured distance "A".
6. Subtract distance "D" from distance "A" to obtain your operating depth.
7. The depth of the main frame is set by use of stop collars on the main lift cylinders (See Fig. 5). A limited number of collars are provided with the cylinder, additional can be obtained from the dealer.

NOTE: make certain that there is an equal length of stop collars on both lift cylinders. Failure to maintain the same retracted length can cause axle and frame problems.

Operate the unit for a number of rounds and recheck desired depth settings. Adjust unit level and depth of operation as required. Once operational depth is reached tighten the locking nut on the leveling adjustment bolt. Check all depth adjustments periodically as the unit is used.

INFIELD LEVELLING

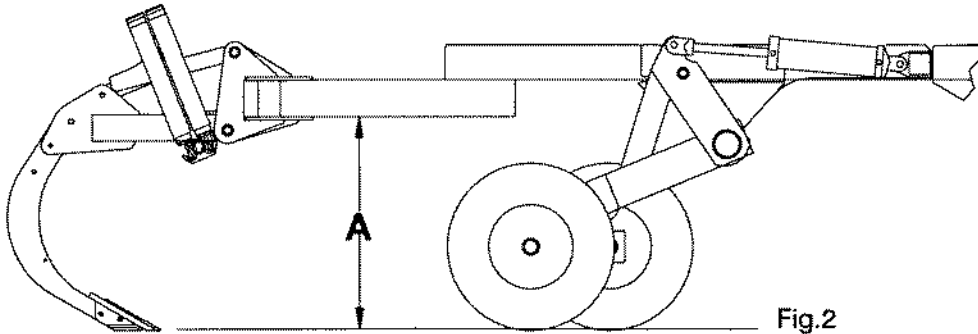

Fig. 2

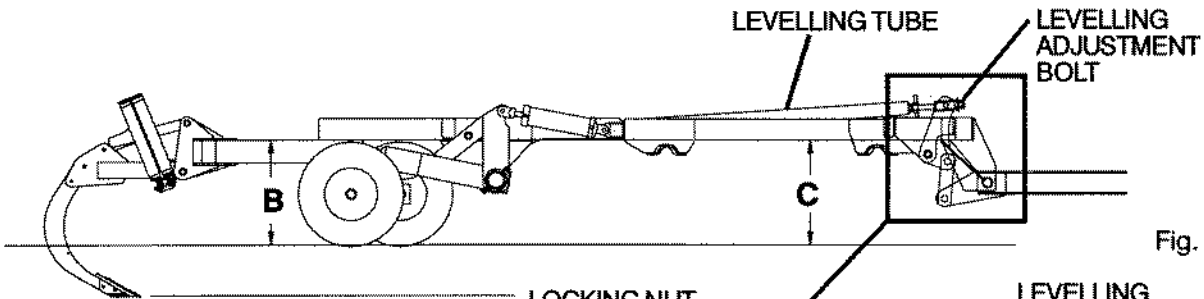

Fig. 3

NOTE: TURNING THE LEVELLING ADJUSTMENT BOLT CLOCKWISE WILL RAISE THE FRONT OF THE UNIT.

NOTE: RECHECK FIELD ADJUSTMENTS AFTER A FEW ROUNDS.

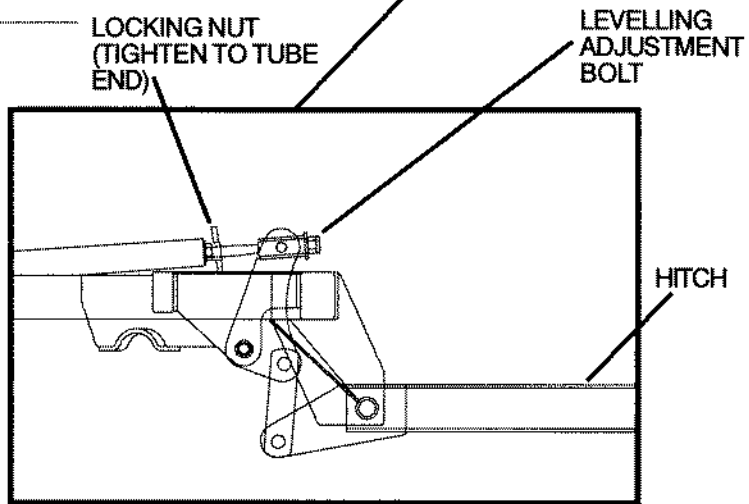

Fig. 4

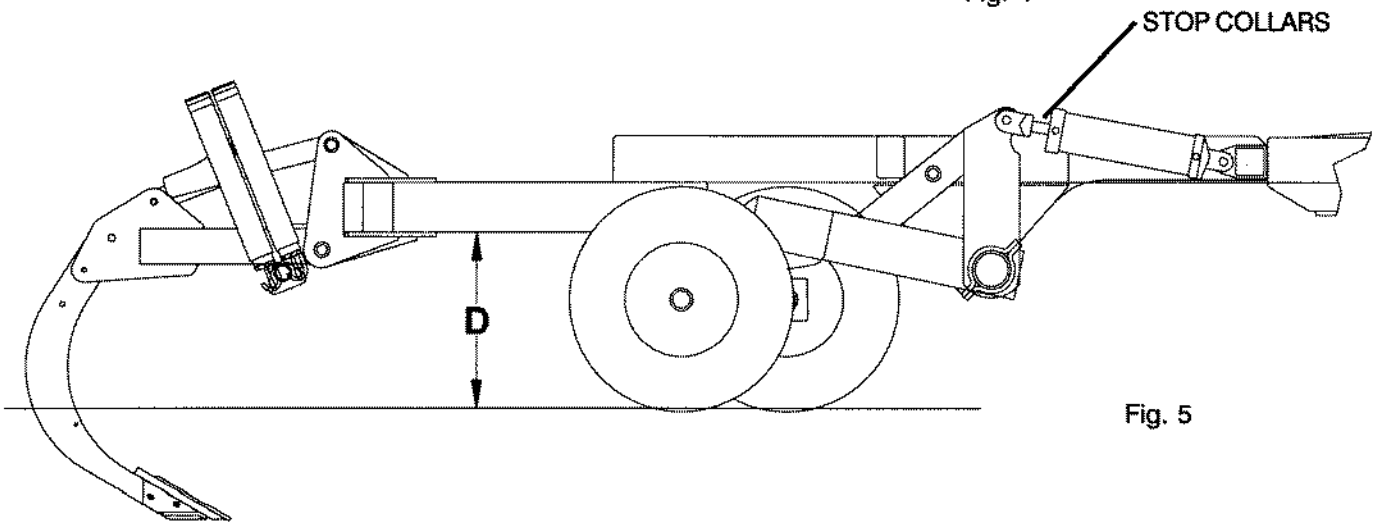



Fig. 5

RIPPER SHANK DEPTH

The ripper shank can be set in the shallow or deep working position by mounting the shank in the upper or lower mounting holes. Mounting in the upper holes will place the shanks at the maximum depth position. Use this position when the maximum shank depth relative to the disk gang depth is desired. By mounting this shank in the lower holes the shank is raised 5" higher. This position is effective when the front disk gangs need to be operated at a deeper depth relative to shank depth.

NOTE: CHECK DIMENSION "A" BETWEEN THE SHANKS, NOT RIGHT NEXT TO THE SHANK. HILLING AROUND THE SHANK CAN GIVE INACCURATE DEPTH READINGS.

	<p>CRUSHING HAZARD KEEP AWAY</p>
	<p>To prevent serious injury or death from crushing:</p> <ul style="list-style-type: none"> • Stay away from shank area when shank is resetting. • Do not try to reset shanks by hand. • Keep all bystanders away.

IN FIELD

1. Set main frame down to where the shanks are resting on the ground, measure distance "A".

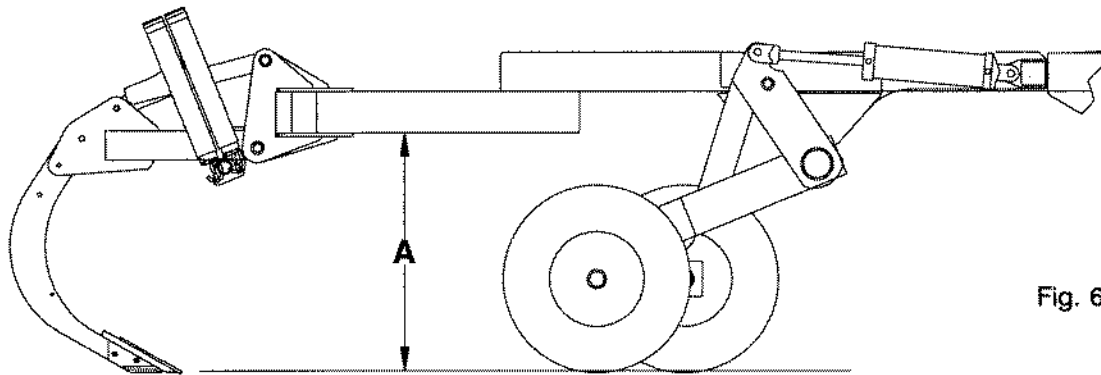

Fig. 6

2. Set Ripper to the working position (pull into ground). Check distance "B" at the same location on the main frame.
3. Subtract both dimensions to get your Ripper shank depth.

4. Set required depth by use of stop collars. Every inch of stop collar added to lift cylinder will raise the machine approx. 2-1/4".

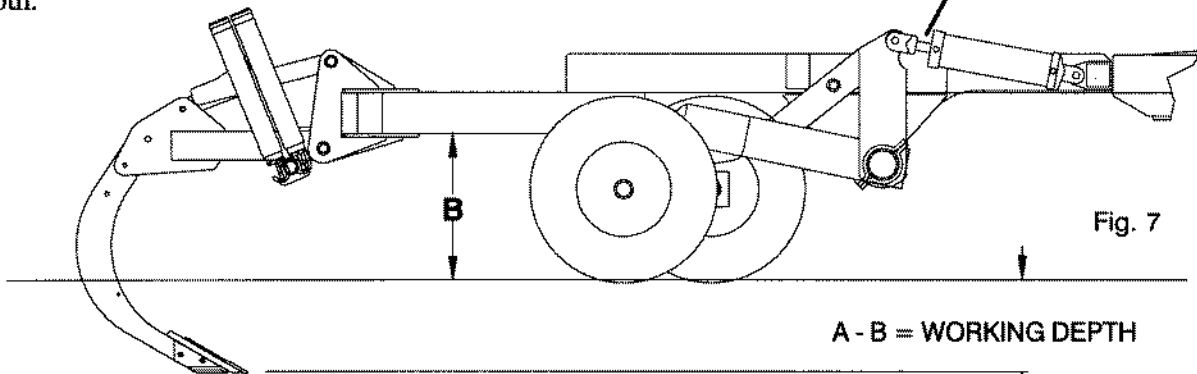

Fig. 7

NOTE: SHANK MECHANISM IS NOT DESIGNED TO FLOAT OUT. IT SHOULD ONLY TRIP WHEN AN OBSTRUCTION IS ENCOUNTERED.

TRIP SHANK TENSION IS SET AT FACTORY AND REQUIRES NO ADJUSTMENT.

NOTE: WIL-RICH DOES NOT RECOMMEND GOING MORE THAN 16" DEEP.

The disk gangs are hydraulically controlled and the can be set by use of a 4 x 12 cylinder (see Fig. 8). This feature allows the disk depth to be changed as conditions dictate. It is recommended that the disk gangs be set at the maximum depth of operation, with the 4 x 12 cylinder fully extended. This will ensure that the front and rear gangs will cut the trash evenly across the width of the machine. The cylinder can be used to vary the depth of the gangs if desired.

The disk gangs are equipped with C-spring pressure relief, to decrease the impact load on the blades and frame in the event of rock or obstruction contact. When working known rocky areas of the field activate the hydraulic lift to raise the gangs to decrease the potential for damage. Once through the problem area, extend the lift cylinder to return the disk gang section to the operating depth.

The adjustable tie rod on the rear disk gang control is adjustable to match varying operating conditions. By adjusting the tie rod to a shorter length the rear disk gang can be raised relative to the front gang. This may be required as ground and trash conditions dictate. Loosen the locking nut, adjust the tie bar length and retighten the lock nut.

DISK GANG DEPTH



**BLADES CAN HAVE SHARP EDGES.
CARE MUST BE TAKEN WHEN WORKING AROUND OR ADJUSTING TO AVOID INJURY.**

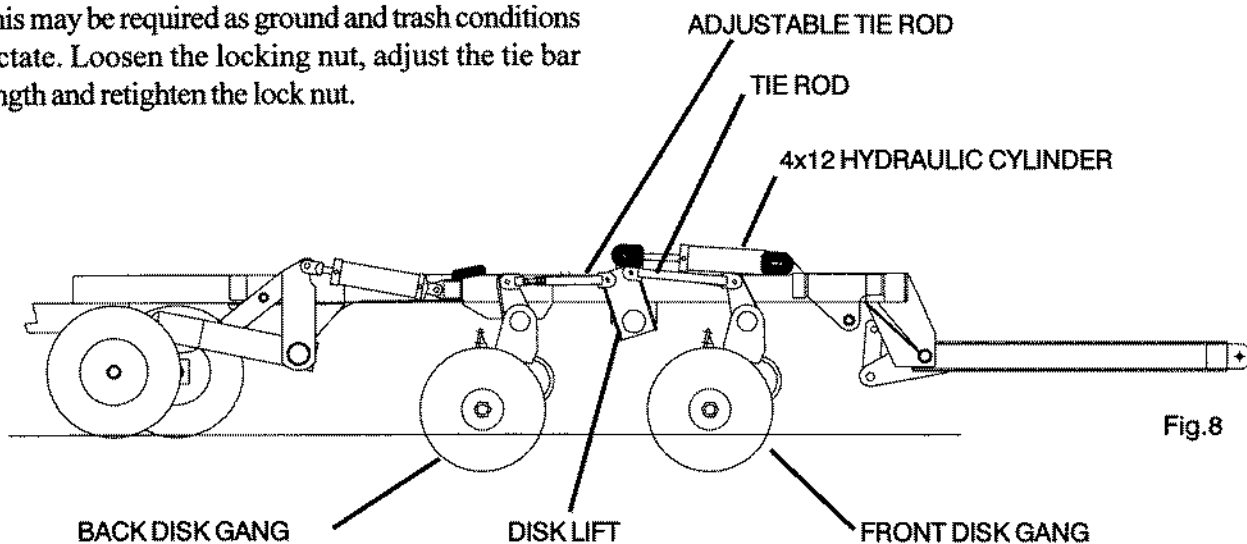

Fig.8

NOTE: THE TORQUE FROM THE REAR SHANKS WILL GENERATE A DOWNWARD FORCE ON THE DISK GANGS AND MAIN HITCH.

BY USE OF THE HYDRAULIC ADJUSTMENT ON THE DISK GANGS ADDITIONAL DOWNWARD FORCE CAN BE PLACED ON THESE GANGS. THE DISC GANGS ARE POSITIONED TO ALLOW TRASH CUTTING AND MIXING DOWN TO THE NOTED DEPTH.

DO NOT ADJUST THE LEVEL OF THE UNIT TO EXCEED THE RECOMMENDED DISK DEPTH AS DISKING OPERATION WILL NOT BE ENHANCED AND DAMAGE TO THE DISK AND FRAME COMPONENTS WILL OCCUR.

TRANSPORT SETTING

The 957 Disk Ripper is equipped with a manual transport lock to be used when transporting the unit. This lock (Fig 9) is mounted to the main lift axle anchor. When operating the unit the lock is rotated to the rear as shown. When transporting the unit the lock should be rotated to the front with the lock tab resting on the top of the lift cylinder barrel.

NOTE: Lock is heavy, handle accordingly when rotating the lock into the transport lock position. Lift cylinders must be fully extended to allow lock to fit properly. Always use both transport locks.

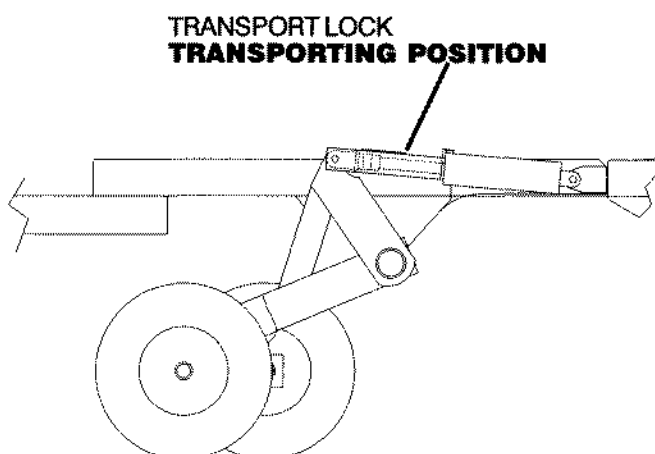
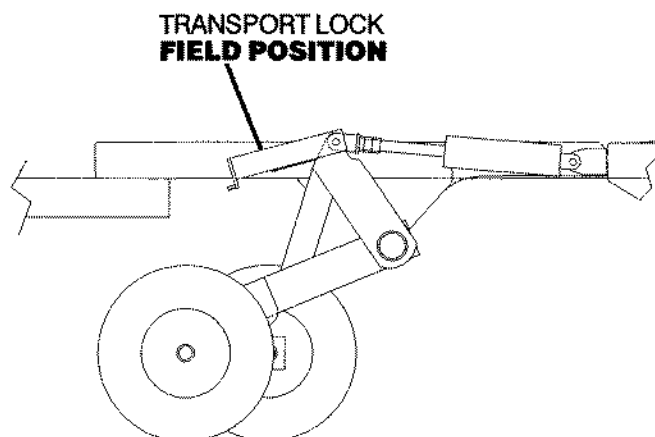
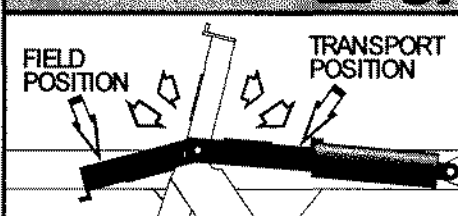

Fig. 9

▲ CAUTION	
	FAILURE TO FOLLOW THIS INSTRUCTIONS MAY RESULT IN PERSONAL INJURY AND/OR EQUIPMENT DAMAGE: <ul style="list-style-type: none">• Always install transport locks on lift cylinders before transporting. <small>222686</small>

PRE 2003 HARROW OPERATION

SECTION LEVEL ADJUSTMENT

To set the harrow working depth, first set the Disk Ripper to its working position. Remove the 5/8NCx4-1/2 GR5 bolt and relocate spacer tube weldment as required. The section should be set to run 3" to 5" deep in the working position.

NOTE: Spacer tube weldment has 3 hole locations and can be rotated 360° for finer adjustments.

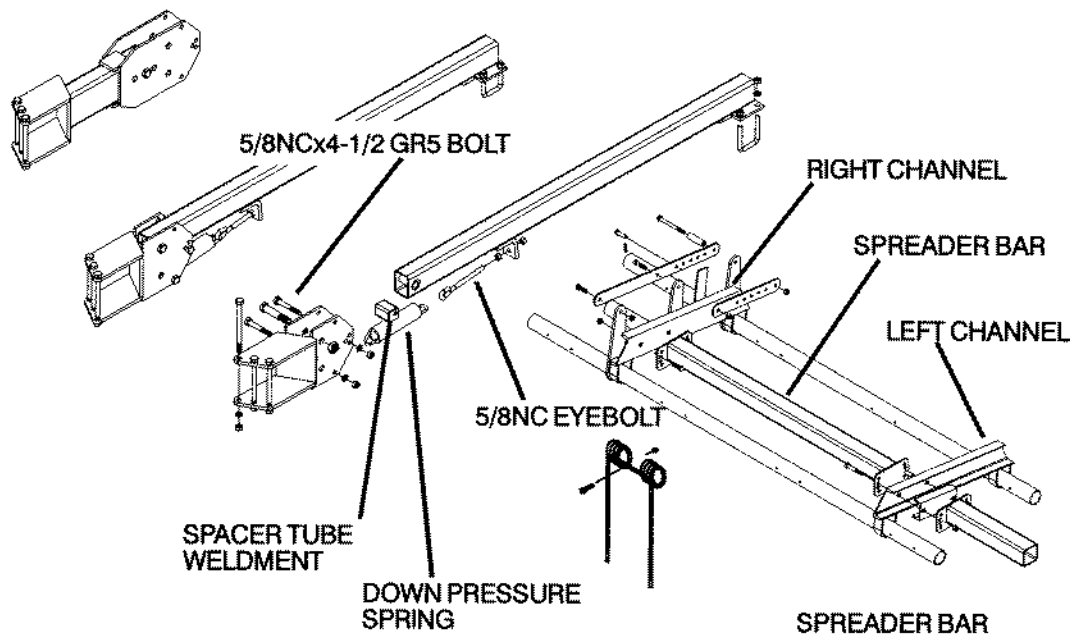
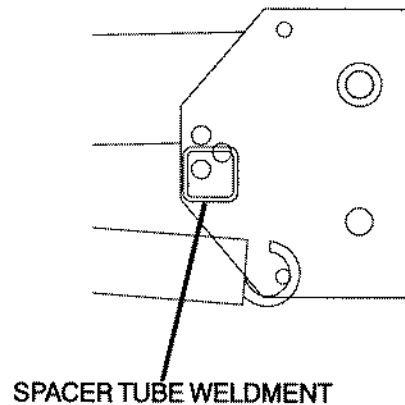

To set the front to rear level of the section adjust the 3x3 spreader bar location as shown below. Remove front or rear bolt in spreader bar and rotate right and left channels until harrow is level. Reinstall bolts and tighten to specified torque.

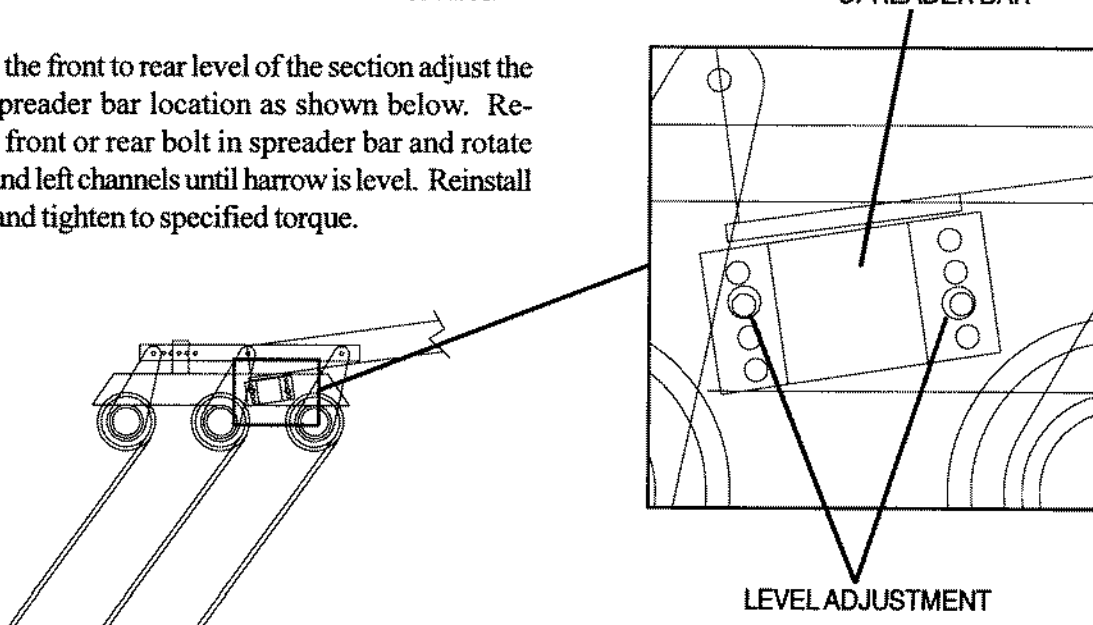

HARROW OPERATION

2004-UP SECTION LEVEL ADJUSTMENT

To set the harrow working depth, first set the Disk Ripper to its working position. Remove the 5/8NCx5 GR5 bolt and relocate as required. The section should be set to run 3" to 5" deep in the working position.

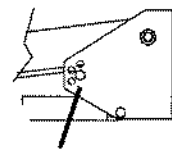

DEPTH ADJUSTMENT BOLT

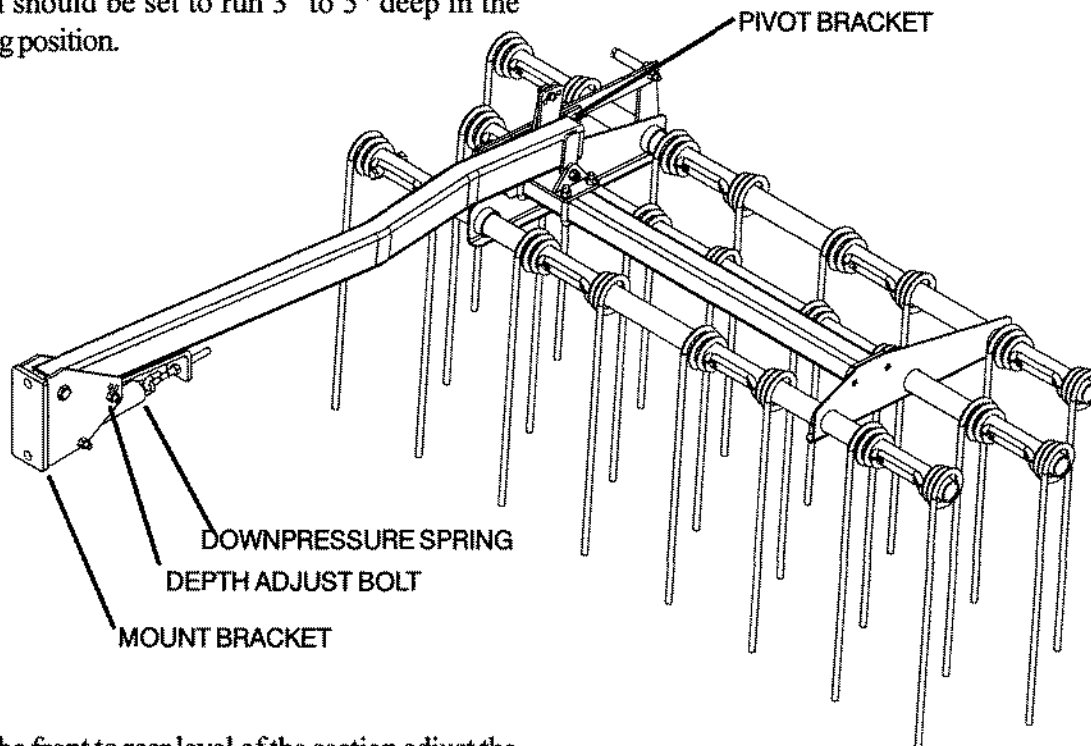

To set the front to rear level of the section adjust the pivot bracket as shown below. Remove the 1/2NCx1-1/2 GR5 bolts and rotate the section until the section is level. Reinstall bolts and tighten to specified torque.

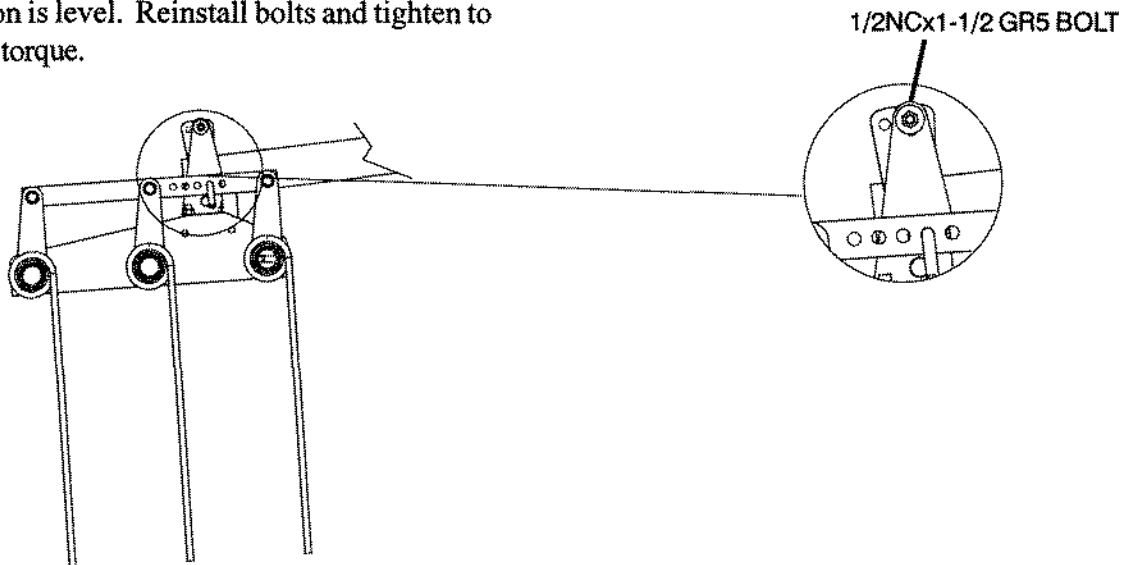

1/2NCx1-1/2 GR5 BOLT

TINE ANGLE ADJUSTMENT

Adjusting the bar linkage to any of the five positions shown below controls the working angle of the tine. Pinning the bar linkage in the rear hole allows the section bars to rotate back to the least aggressive position. This position will allow trash to move more easily through the harrow with reduced soil mixing.

Pinning in the front holes will set the tine angle to its most aggressive position. Setting the harrow at the aggressive setting will allow the harrow to move more soil and knock down ridges, but will be less tolerant of trash.

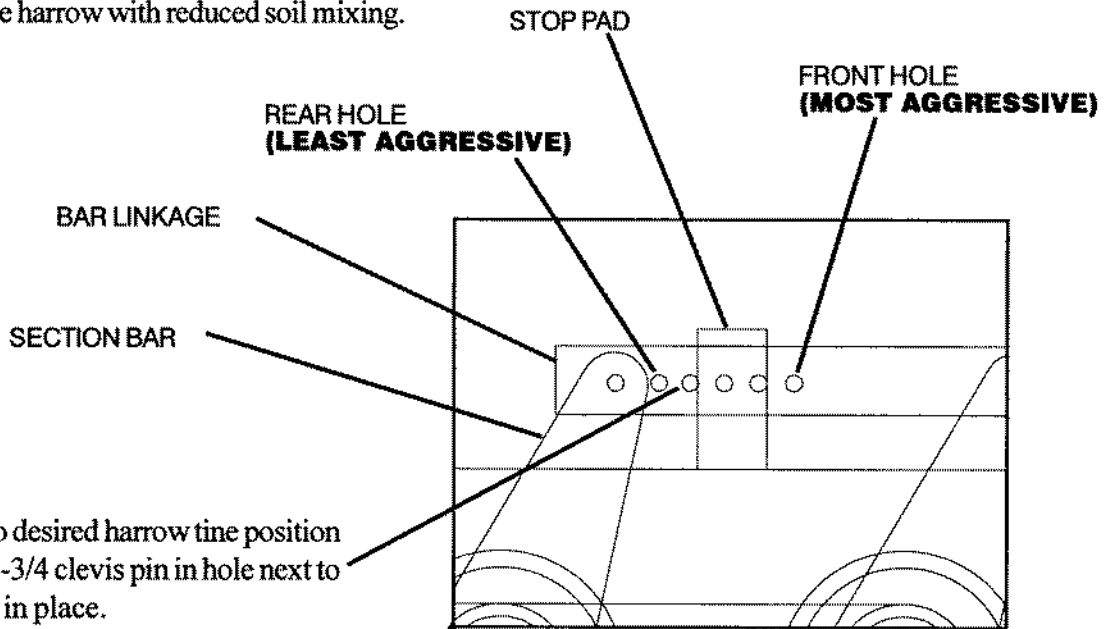

Set bar linkage to desired harrow tine position and install 1/2x1-3/4 clevis pin in hole next to stop pad to lock in place.

MOST AGGRESSIVE

The down pressure spring should be adjusted so spring coils are slightly apart. If more down pressure is required adjust 5/8NC eyebolt accordingly. **Do not over-tighten, harrow sections must be able to float over obstructions.**

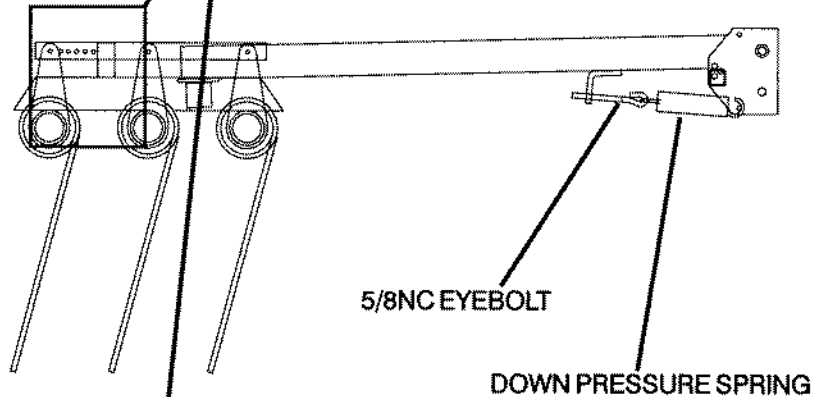

LEAST AGGRESSIVE

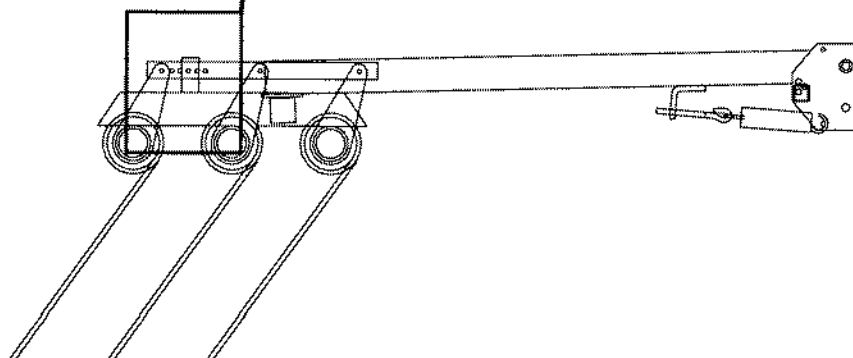

This page was intentionally left blank

LUBRICATION

Always lubricate your Disk Ripper thoroughly before taking it to the field.

Grease fittings are provided at all points indicated in illustration below.

Be sure all fittings are free of dirt and paint so clean lubricant is certain to enter the proper areas. If grease fittings are damaged or missing, replace them immediately. Clean the fittings thoroughly before using the grease gun.

It is recommended to use **Wil-Rich 460ep Tillage Lubricant** in your 957 ripper. It is specifically designed for the loads and conditions encountered in heavy tillage. It is available for your Wil-Rich Dealer. Grease at the hourly intervals indicated on the symbols.

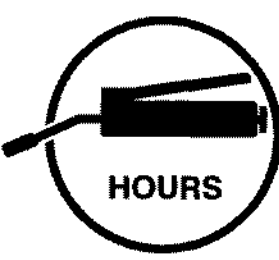

Lubricate with grease at hourly interval indicated on symbol.

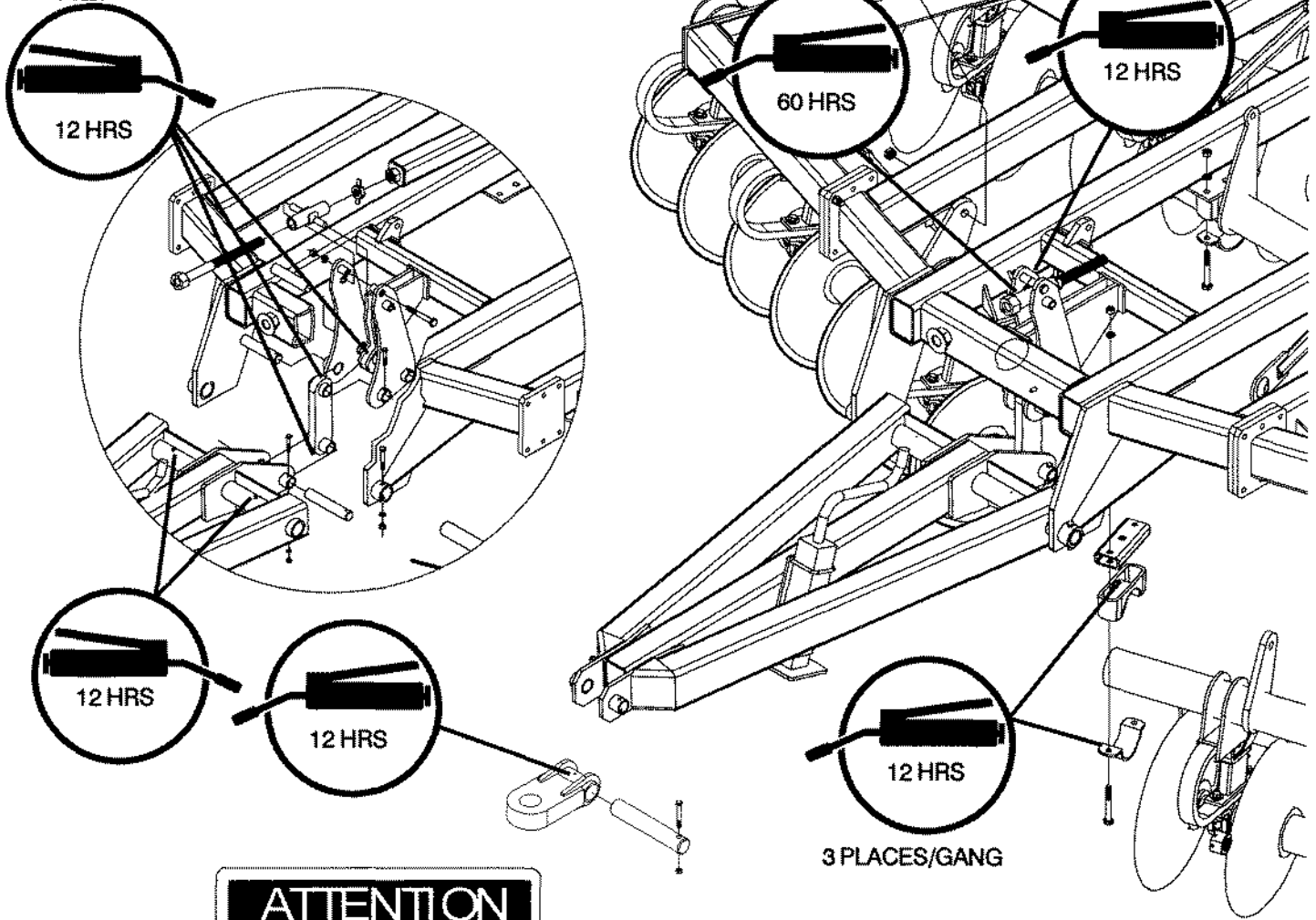

ATTENTION
Grease Fittings
62557

ATTENTION
Grease Fittings
0257

12 HRS

12 HRS

12 HRS
6 PLACES

20 HRS

FILL
10 HRS
ALL BEARINGS/GANG

12 HRS
HUB

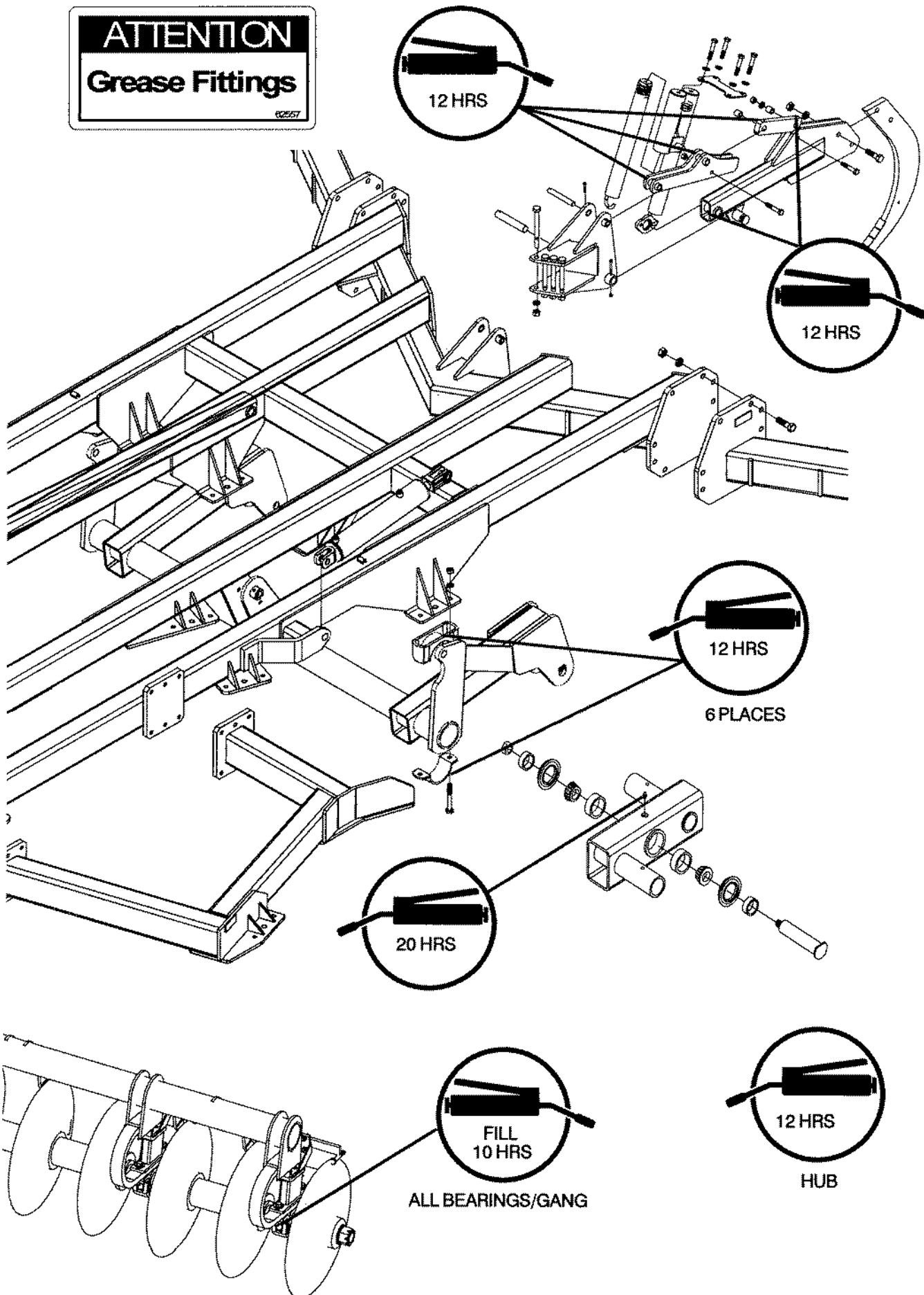

RECOMMENDED FIELD-GREASING PROCEDURES-957 DISC BEARING

Bearings are filled with **Wil-Rich 460ep Tillage Lubricant** at the factory. It is recommended that the bearings be filled with grease every 10 hours of use. **WHEN GREASING THE BEARING, USE ONLY A HAND OPERATED GREASE GUN AND GREASE THE BEARING VERY SLOW.** A small amount of grease coming out past the seal should not ruin the seal, as contaminants in the seal lips should be expelled. But greasing at a fast rate can raise the internal pressure and compromise the seal.

It is recommended to use Wil-Rich 460ep Tillage Lubricant grease in your 957. It is designed specifically for the loads and conditions encountered in heavy tillage.

At the end of the season when preparing for winter storage **SLOWLY GREASE THE BEARING** until the grease pushes past the seal to clear the lips of the seal and extrude any moisture. If you have any questions about the greasing procedure of the grease used contact your dealer.

TROUBLESHOOTING

PROBLEM	POSSIBLE CAUSE	SOLUTION
Unit will not go into ground.	<p>Incorrect leveling of machine when at operating depth.</p> <p>Worn points.</p>	<p>See leveling, page 13.</p> <p>Replace point.</p>
Shanks will not reset.	<p>Worn points</p> <p>Inadequate lubrication of trip components.</p> <p>Damaged trip components.</p>	<p>Replace point.</p> <p>Lubricate parts.</p> <p>Remove and replace damaged parts</p>
Machine pulls hard	<p>Blades are too deep.</p> <p>Shanks are too deep.</p> <p>Dull points.</p>	<p>Excessive depth consumes power.</p> <p>Replace</p> <p>Inflate tires to noted P.S.I.</p>
Breaking points.	Working speed too fast.	Slow Down.
Machine pulling crooked.	<p>Unequal tire inflation</p> <p>Lift cylinders adjusted different</p>	<p>Inflate tires to Noted PSI</p> <p>Use equal amount of stop collars (Page 14).</p>
Poor penetration	<p>Dull or broken shank points</p> <p>Machine not level</p> <p>Blade depth is too great. Holds or causes shanks to float out.</p>	<p>Replace points</p> <p>Level machine</p> <p>Decrease blade depth. See page 15.</p>
Blades won't go deep enough.	<p>Machine is not level.</p> <p>Dull blades</p>	<p>Level machine.</p> <p>Sharpen/replace</p>

%DeleteMe